

collection 2014/15



www.sporten.cz

alpine
nordic

SPORTEN



sporten team	▼	2
technology	▼	4
racing specials	▼	5
how to choose the right alpine skis	▼	9
exclusive	▼	10
alpine skis sport	▼	12
alpine skis power fit	▼	17
alpine skis lady	▼	19
alpine skis fun	▼	21
alpine skis junior	▼	24
alpine skis kid	▼	28
how to choose the right nordic skis	▼	30
nordic skis sport	▼	31
nordic skis power fit	▼	35
nordic skis touring	▼	38
nordic skis lady	▼	40
nordic skis junior and kid	▼	42
nordic skis backcountry	▼	44



TOMÁŠ JAKOUBEK (Nordic skiing)

2012 – 3rd place Marcialonga Combined, 2011 – 2nd place Marcialonga Combined, 2010 – 1st place Marcialonga Combined, 2010 – 36th place Vasaloppet, 2009 – 19th place Jizerská 50

“I like doing sports, I love skiing, I enjoy racing and I hate losing! I owe my racing success as well as my pleasure in high performance skiing to Sporten!”



VLADĚNA PUSTKOVÁ (ski jumping)

2012 – 2nd place Czech Championship, 2012 – 6th place World Cup (Mixed teams) Lillehammer, 2011 – 1st and 2nd places Czech Championship

“My Sporten skis are always custom-made, precisely according to my requirements and needs. I am very happy to be part of the Sporten team – a big THANK YOU to Sporten for everything they have done for me.”



JULIA KYKKANEN (ski jumping)

2012 – 3rd place in Continental Cup Norway Lillehammer, 2012 – 8th place in Junior World Champions Turkey Erzurum, 2010 – 6th place in Continental Cup Norway Notodden

“My thanks to Sporten who is making the best skis I can have at highest quality! I’m really grateful to Sporten that I have the opportunity to jump with your skis!”



JERE KYKKANEN (ski jumping)

2012 – 1st place Eau Claire USA 5 hills tournament, 2012 – 3rd place Finnish championship Rovaniemi, 2012 – 12th place COC Iron Mountain

“Sporten skis feel awesome and every pair I get is perfect and exactly what I order and want. Sporten has really good material for skis. All pairs are really fast in the run-up – the ski base material is really the best I know and allows me a really good speed all the time.”



PETR KOTAL (Nordic combined)

2009 – 3rd place Czech Championship (Men), 2009 – 3rd place University games Harbin, 2006–1997 – 12 times 1st place – Czech Championship (Learners/Juniors)

“Thanks to Sporten I can rely on my skis even at speeds reaching to 100 km per hour, four meters above the ground.”



LADISLAV POKLUDA (alpine skiing)

2011 – 1st place Czech Masters Cup, 2010 – 3rd place WC FIS Masters CUP, 2010 – 3rd place Masters Bled First World Winter Games

“My big thanks to Sporten for their attitude to my racing. I have the best conditions and the best quality skis I have ever ridden.”



FILIP SAKALA (ski jumping)

2012 – 2nd place Czech Championship, 2012 – 6th place Fis Cup Brootleboro, USA, 2012 – 10th place, Fis Cup Wisla, 2011 – 1st place Czech Championship

“Thanks to Sporten I have managed to join the Czech national junior team and to win several races on my Sporten skis. The skis made for me by Sporten allow me to keep on improving.”



DROPIT.CZ

Tomáš Vrbický (freeride)

Martin Vrbický (filmmaker, freeride)

Honza Doubek (freeride)

Paulie Drašík (traveller, adventurer)

Dropit riders simply love any kind of snow riding – from freeride to skicross to speedski. They are people for whom snow means life and who inform you at www.dropit.cz of everything that's going on in the world of skiing, in the Czech Republic and worldwide. The team includes SX national representatives, freeriders as well as a reputed filmmaker.

“Sporten has been supplying us for long with quality freeride material without which we would be unable to enjoy our sport. It is always a surprise what premium quality the skis are. We are proud they are Czech made ☺ In short, ‘Support the locals!’”



JOSEF HEPNAR (ski-alpinism)

2012 – 1st place Mountain Rescue Services International Race, 2012 – 3rd place Central European Cup in Pilsko, Poland, 2012 – 3rd place Czech Championship in Špindlerův Mlýn

“I hope there will always be support on the part of Sporten as well as pleasure and excitement on our part and that we are able to represent Sporten in the long run. Why? Sporten has been our best choice ever!”



JAN HEPNAR (ski-alpinism)

2012 – 5th place Central European Cup Janské Lázně, 2012 – 3rd place Central European Cup Rokytnice nad Jizerou, 2012 – 4th place 3-day race in West Tatra Mountains (Bokami Západních Tater)

“Sporten skis have been driving me uphill and downhill faster and faster for three years and I sincerely hope they will keep doing so in the future. Thanks to them I am able to climb still higher peaks.”



TITANAL

Titanal plate® is a high strength, age hardenable aluminum-wrought-alloy that significantly increases the torsional rigidity and edge grip of a ski providing smooth running. It is used in combination with or instead of a certain type of fiberglass.



PREPREG

A specially produced type of high-resistance fiberglass ensuring maximum power transfer to the edge.



WOODCORE

A typical laminated high-quality woodcore. Lightweight woodcores of cross-country skis with air channels to save weight.



ULTRALIGHT WOODCORE

Low weight wooden material suitable for the given ski category, respecting required qualities of the wooden core (i.e. in particular flexibility).



POLYFLY

Special PU composite makes a perfect stable core providing excellent dampening characteristics.



3D SHAPE

Contributes to the overall torsional rigidity of alpine skis and to better aerodynamics of both alpine and cross-country skis.



STRUCTURED TOP SHEET

The highly esthetic top sheet increasing the scratch-resistance of skis.



HONEYCOMB

A material minimizing the weight of cross-country racing skis.

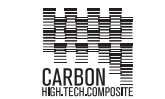

CARBON HIGH TECH COMPOSITE

Carbon is used in construction in order to achieve lower weight altogether with increasing of reaction capabilities of both skis and snowboards.



DOUBLE RADIUS

By applying a new technology of two different radiuses, we have succeeded in developing truly universal skis. Smaller radius in the front allows for easy switching between long and short turns. Bigger radius provides for faster completion of the turns and ensures perfect stability in longer turns.



STEEL EDGES

Steel edges on Nordic skis are a great help in controlling the skis on frozen surface, mainly in downhill rides. They are suitable mainly for skiing on ungroomed tracks. Plus, steel edges extend the skis' life significantly.



ROCKER

Rocker (front part of the ski lifted slightly upwards) is a construction element used for two reasons: 1) Better stability in deep snow. Appreciated especially by free riders. 2) Significant help on the start of a turn. Generally easier and more comfortable control of skis on the piste.

UHM NANO GRAPHITE RACE BASE

Graphite base with ultrahigh molecular weight, manufactured by using nanoparticles. Exceptional sliding parameters suitable for most conditions thanks to several special additives. All combined, these qualities ensure maximum wax absorption. This base is used exclusively for racing skis. For keeping the proper qualities of the base, the skis require expert service.

UHM GRAPHITE RACE BASE

Graphite base with ultrahigh molecular weight. Offers excellent wax absorption and ensures a perfect glide. This base is used for sport and high performance skis. It requires regular care using gliding wax to prevent any damage.

HM GRAPHITE BASE

Graphite base with high molecular weight for sport skis. The base contains higher amounts of wax-based additives plus several other additives ensuring a very good glide. To keep the proper sliding qualities, this base also requires regular care with gliding wax, ideally every day you go skiing.

HM EXTRUDED BASE

Improved extruded base with high molecular weight. Even with minimum care, this base keeps its qualities for a very long time, ensuring maximum comfort. Depending on the frequency of use, we recommend impregnating the base with paraffin wax at least once in 2 weeks.

EXTRUDED BASE

Technology adapted to the needs of occasional skiers where comfort is the principal parameter rather than glide, as well as keeping the proper qualities of the base for as long as possible while requiring least effort on the consumers' part. For skis in this category, we recommend expert service one or two times during a season.

racing specials



collection 2014/15



www.sporten.cz

SPORTEN

ahv 06 GS/SG



ahv 06 SL



bohemia race classic - sr./jr.



bohemia race skate - sr./jr.

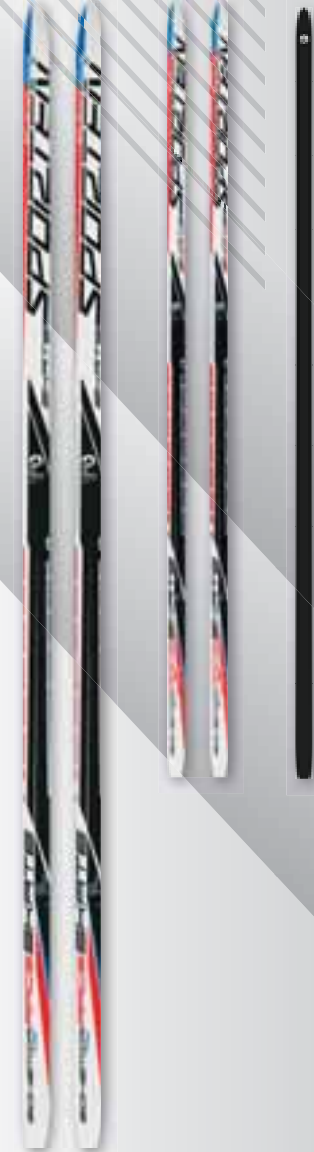

Products in this section are determined for racing and are produced according to individual requirements. They have to be ordered till the end of March and certain minimum quantity (all orders) has to be achieved. To find out more go to www.sporten.cz

guru



sbx race evo II



aerials



jump skis



Products in this section are determined for racing and are produced according to individual requirements. They have to be ordered till the end of March and certain minimum quantity (all orders) has to be achieved. To find out more go to www.sporten.cz

collection 2014/15



www.sporten.cz



alpine

how to choose the right alpine skis

**EASY-GOING SKIER:**

Skiing? Sure if the weather, mood and guys around are fine... and if there're enough refreshment points by the piste! You spend around 7 days and 2 weekends in a year skiing.

**FITNESS SKIER:**

Skiing is great fun! When you're in the mood, you can't get your feet off the slope. Still, enough is enough, mountains are not just skis. You spend around 7 - 14 days in a year skiing, plus weekends if the people and place are right.

**HIGH PERFORMANCE SKIER:**

Sweat and hard work is part of skiing. You like to relax, but you need to earn it. You want to rely fully on your skis, you want them to support you to the limit. You spend 14 or more days in a year skiing, plus weekends on a regular basis.

**RACING SKIER:**

Skiing is your life. You're headed for victory. If the skis don't suit you, it's their bad luck, not yours. Which, however, doesn't happen as you know exactly what you expect from them. You ski according to a training plan, your season starts with the first snow.

exclusive alpine



collection 2014/15



www.sporten.cz

universum



BASE: UHM Graphite race base

As a cutting edge technologies fan I don't settle for any ordinary "planks" on the piste. A superb design is a nice thing, but I need to know what's inside. Only skis with a modern construction will support me in every situation. Nick N., 27 years



UNIVERSUM – Skis equipped with cutting-edge 3D technology based on the traditional sandwich construction with Titanal plates. Double radius for both short and mid-length turns. 73 mm under the binding will support you on wrecked slopes. A tough and uncompromising universal model requiring extra force. Not for easy goers.

length	profile	radius
160	123-73-105	10,9/13,1
168	123-73-105	12,1/14,7
176	123-73-105	13,5/16,8

TUNING: 0,75° and 89°

SET: binding PRD 11 | plate PowerRail

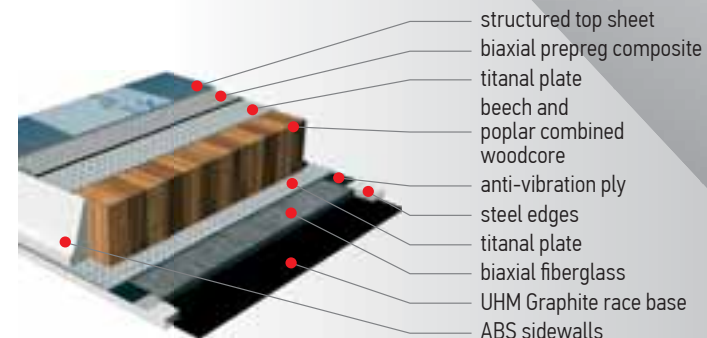

sincro



BASE: UHM Graphite race base

There are slopes where I could go with my eyes tied, and they are still fun. This ski allows me to enjoy every ride in a slightly different way. First I go at full speed, later I carve a nice turn... And when on the lift, I admire the ski's design.

Petr K., 32 years



SINCRO – Original style ski with a light-weight construction. Width over 70 mm and double radius ensure comfort at high speed and stability in turns.

length	profile	radius
159	120-70-104	10,7/13,6
167	120-70-104	12,0/15,0
174	120-70-104	12,9/17,0

TUNING: 0,75° and 89°

SET: binding PRD 11 | plate PowerRail

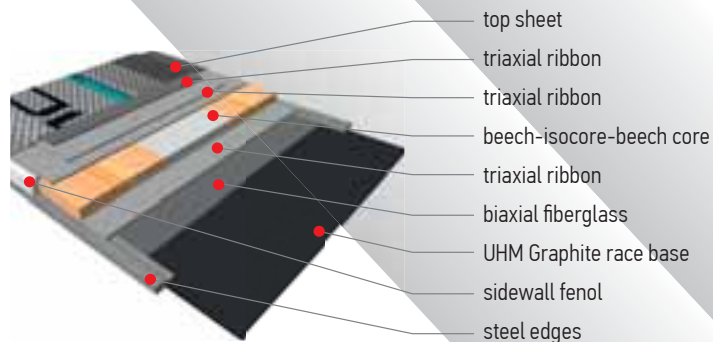

irridium



BASE: UHM Graphite race base

I like everything under control, especially when I ski. A progressive start of the turn and then quickly out again... With Iridium, I can be sure my skis will never let me down.

Joe, 26 years



IRIDIUM – Universal skis for real connoisseurs. Width over 70 mm and double radius ensure comfort at high speed and stability in turns.

length	profile	radius
160	123-73-105	10,9/13,1
168	123-73-105	12,1/14,7
176	123-73-105	13,5/16,8

TUNING: 0,75° and 89°

SET: SET: binding PR 11 | plate PowerRail

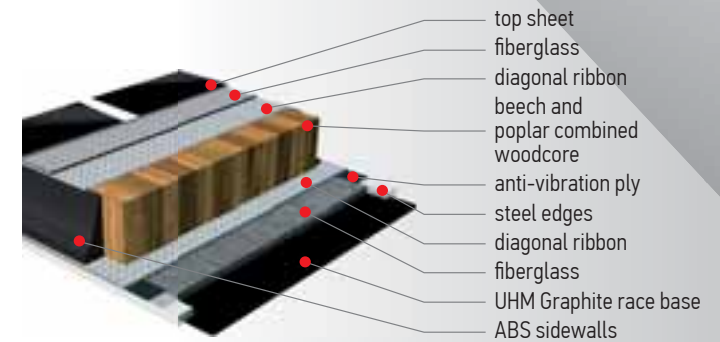

12-13

sport
alpine

ahv 06 GS



collection 2014/15



www.sporten.cz



BASE: UHM Graphite race base

I love speed! I've been training various ski riding techniques and of course my shape for all my life. A hard slope is unforgiving – there's no room for even the smallest error. Whenever I put my skis on, it's just me and them.

Daniel, 46 years



AHV 06 GS – Skis that love speed on a hard, well-groomed piste while offering extraordinary stability.

length	profile	radius
175	117-71,5-101,5	17,7
180	116,5-71,5-101	19,1
185	115-71,5-99	21,3

TUNING: 0,75° and 88°

SET: binding Free Flex 14 | plate Speedplate Plus

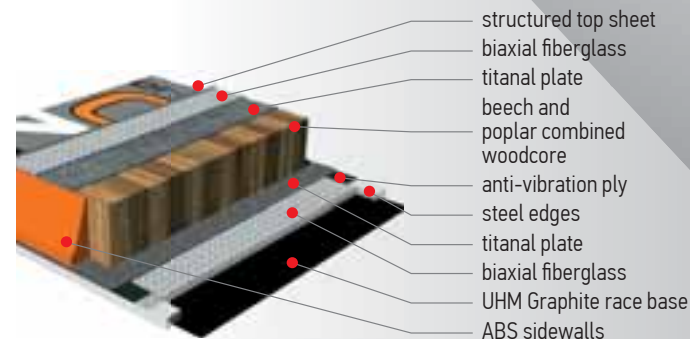

WOOD.CORE

TITANAL

structured top sheet

ahv 06 SL

ahv 05 SL



BASE: UHM Graphite race base

When I was little, other boys used to ride snow plough style. Not me – I started doing turns right away! That's what I've been doing ever since. And what makes me even happier? Add a few slalom poles in between! Now that's what I call a ride!

Michael, 29 years



AHV 06 SL – Fast curving skis for aggressive style in turns.

length	profile	radius
155	121-67-104	10,7
160	121-67-104	11,5
165	121-67-104	12,4

TUNING: 0,75° and 87°

SET: binding Free Flex 14 | plate Speedplate Plus

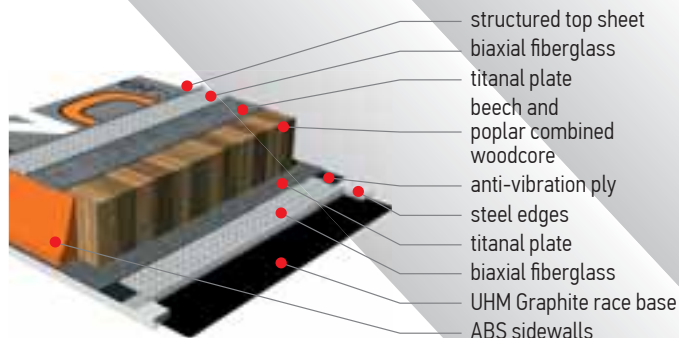

BASE: UHM Graphite race base

I'm a skier body and soul, only there's still less time for skiing now. Work, family, kids, you know. So when I go skiing, I want to enjoy my skis as much as I can. I want them to go at racing speed, but I also want to relax in an easy ride.

Tom S., 42 years



AHV 05 SL – High performance skis for skiers not content with only one style. Ideal for short to mid-length turns.

length	profile	radius
155	121-67-104	10,7
160	121-67-104	11,5
165	121-67-104	12,4

TUNING: 0,75° and 87°

SET: binding Free Flex 11 | plate Speedplate Plus

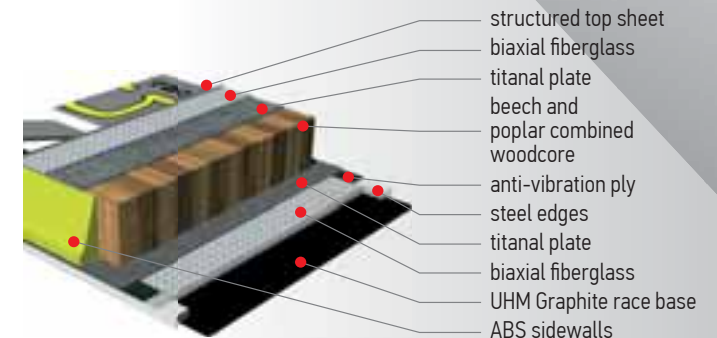

ahv 04 SL

warrior



BASE: HM Graphite base

My friends and I have been going on ski trips since school even several times in a season. We always ski to the full – no time for partying. I can't wait to beat the boys in slalom again!
Marsha T., 19 years



AHV 04 SL – Easy-to-control slalom skis with maximum tuning for a variable riding style. Satisfaction guaranteed even for high performance focused skiers.

length	profile	radius
155	121-67-104	10,7
160	121-67-104	11,5
165	121-67-104	12,4

TUNING: 0,75° and 89°

SET: binding PR 11 | plate PowerRail

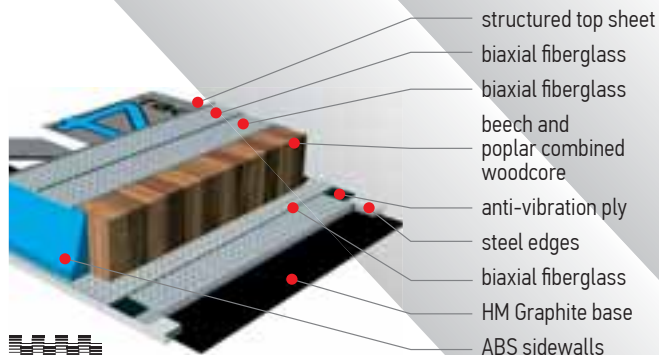

BASE: HM Graphite base

I don't get off the track until I've done some really hard work. Relaxed riding just bores me to death. For me, skis are the greatest challenge. Everything else is a waste of time!
Alex A., 24 years



WARRIOR – Hardened dynamic ski for all types of conditions. Sandwich construction with Titanal plates. For strong aggressive skiing on edge.

length	profile	radius
159	120-72-102	12,7
168	120-72-102	14,8

TUNING: 0,75° and 89°

SET: binding PRD 11 | plate PowerRail

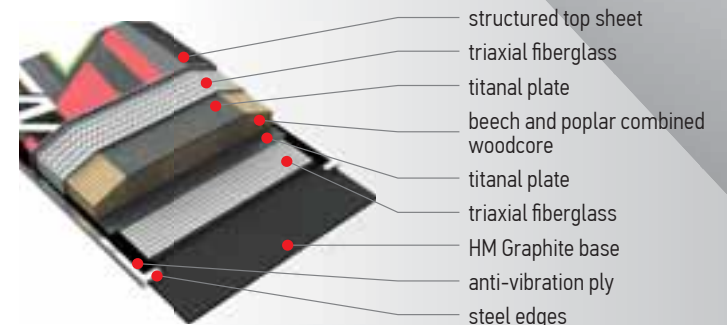

raptor

chrono



BASE: HM Graphite base

What do I like most about skiing? That I'm always master of the situation. But that's not for nothing, there are years of hard work and sweat behind me... And also years of experimenting – until I found RAPTOR at last!

Michael P., 33 years



RAPTOR – Universal sport skis for all types of conditions. Stable in downhill rides, turns, on bumps as well as wrecked slopes.

length	profile	radius
150	120-72-102	11,4
159	120-72-102	12,7
168	120-72-102	14,8

TUNING: 0,75° and 89°

SET: binding PR 11 | plate PowerRail

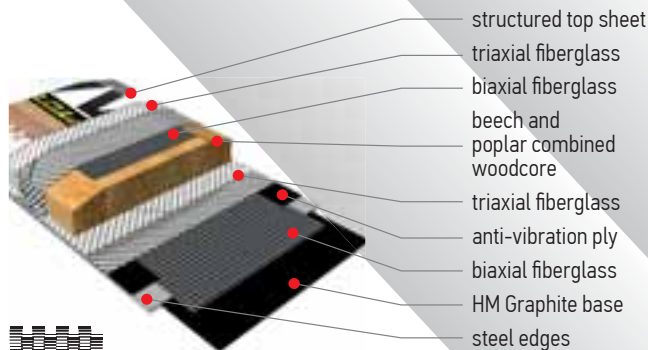

BASE: HM Graphite base

At my age, I don't need chasing after high performance results or showing off in front of girls. I don't need to be a world champion to enjoy a perfect ride. Still, I like when girls turn around (to look at my skis, for example...)

George P., 56 years



CHRONO – Skis with a modern 3D construction for both high performance and relaxed skiing which supports even greater weight. Ideal performance/price ratio.

length	profile	radius
158	116-69-100	13,1
168	116-69-100	14,8

TUNING: 0,75° and 89°

SET: binding PR 11 | plate PowerRail

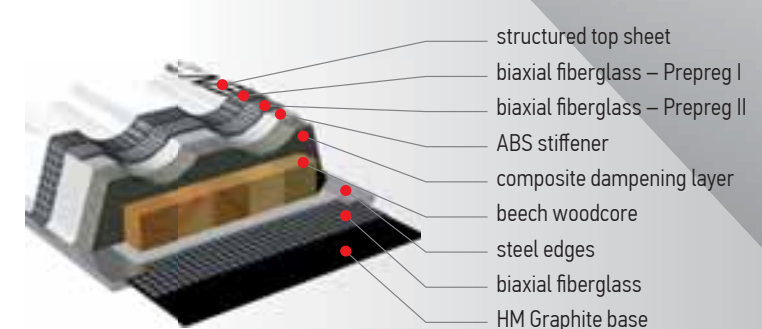

alpine skis

glider

16-17

sport
SPORTEN



BASE: HM Graphite base

Before I bought this ski, skiing on ungroomed tracks used to be an ordeal. I had to get up early to catch the smooth morning piste. But now, I don't care anymore. Melted snow, powder, snowdrifts – nothing is a problem.

David A., 24 years

GLIDER – Comfortable top category skis for universal use. 70% slope, 30% powder. Wooden construction with Rocker system offer support in deep snow.



length	profile	radius
154	124-81-111	12,2
162	124-81-111	13,8
170	124-81-111	15,4
178	124-81-111	17,1

TUNING: 0,75° and 89°

SET: binding PRD 11 | plate PowerRail

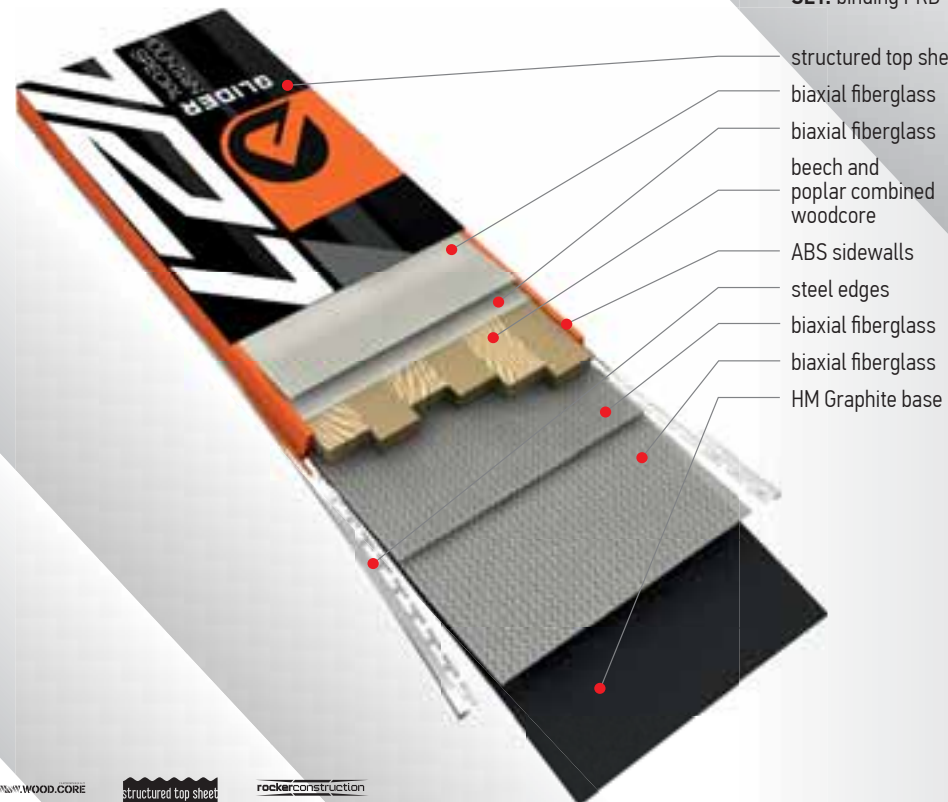

WOOD.CORE

structured top sheet

rockarconstruction

collection 2014/15

power fit alpine



www.sporten.cz

krypton



BASE: HM extruded base

Let me tell you something – who needs toiling on skis when there's enough toiling at work the whole year round? When I go skiing, I'm simply an easy rider. Which doesn't mean of course I don't enjoy curving some perfectly round turns!

Greg M., 39 years



KRYPTON – Reliable sturdy skis that will adapt to your technical skills and forgive possible errors. New shape for better control even on worse quality surfaces.

length	profile	radius
142	119-72-103	9,6/10,4
150	119-72-103	11/11,7
158	119-72-103	12,4/13,2
166	119-72-103	14/14,7

TUNING: 0,75° and 89°

SET: binding PR 11 | plate PowerRail

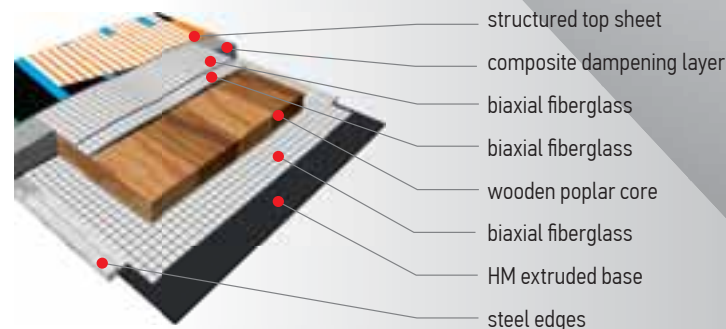

WOOD.CORE

3D shape

PolyFly

structured top sheet

cobalt orange

cobalt green



BASE: extruded base

Going on ski trips means fun time for me and my schoolmates! Bar, disco, party through the night, you know. The next day I'm glad I don't trip off the skis... I'm lucky I can rely on Cobalt at all times!

Wendy, 17 years



COBALT – Tolerant, easy-to-control carving skis for calm riding. New shape for better control even on worse quality surfaces.

length	profile	radius
142	119-72-103	9,6/10,4
150	119-72-103	11/11,7
158	119-72-103	12,4/13,2
166	119-72-103	14/14,7

TUNING: 0,75° and 89°

SET: binding SX 10 | plate Power plate 9

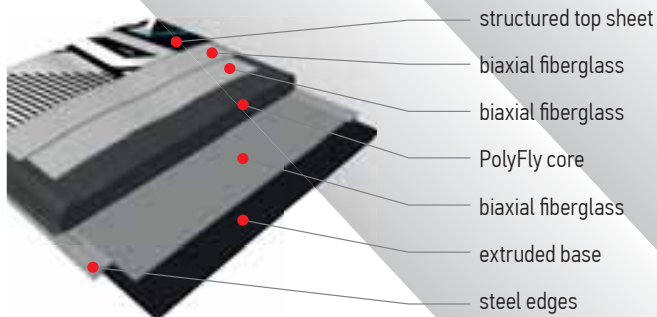

BASE: extruded base

Going on ski trips means fun time for me and my schoolmates! Bar, disco, party through the night, you know. The next day I'm glad I don't trip off the skis... I'm lucky I can rely on Cobalt at all times!

Wendy, 17 years

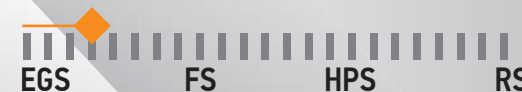

COBALT – Tolerant, easy-to-control carving skis for calm riding. New shape for better control even on worse quality surfaces.

length	profile	radius
142	119-72-103	9,6/10,4
150	119-72-103	11/11,7
158	119-72-103	12,4/13,2
166	119-72-103	14/14,7

TUNING: 0,75° and 89°

SET: binding SX 10 | plate Power plate 9

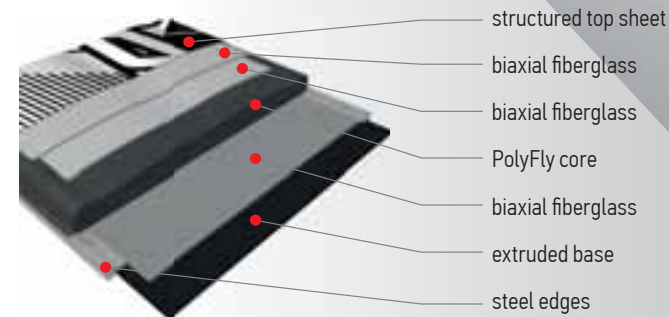

collection 2014/15



www.sporten.cz

lady alpine



sensual



BASE: HM Graphite base

It kept me long to polish my technique. But now, I can say I enjoy every move on the piste. And a perfect riding style goes together with a perfect construction as well as original design of the skis.

Christine ☺, 26 years



SENSUAL – Stylish universal skis with cutting edge technology for a high performance style. Ladies version of RAPTOR.

length	profile	radius
150	120-72-102	11,4
159	120-72-102	12,7

TUNING: 0,75° and 89°

SET: binding PR 11 | plate PowerRail

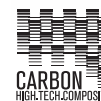
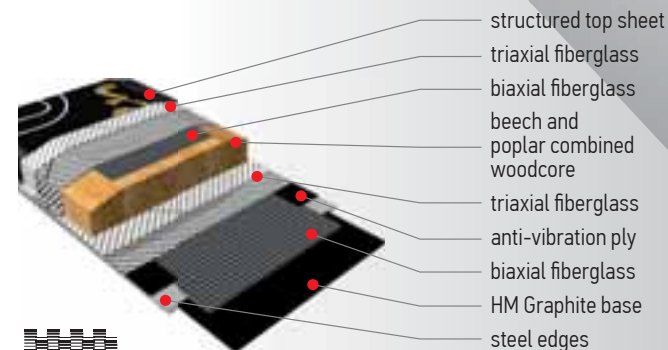

illusion



BASE: HM extruded base

I've already learned to like carving a long time ago. What's so great about it – rather than having to concentrate on every turn, now I can think of how good I look on my skis...

Janet T., 35 years



ILLUSION – Elegant lady skis offering certainty, stability as well as experience on the edge. New shape for better control even on worse quality surfaces.

length	profile	radius
142	119-72-103	9,6/10,4
150	119-72-103	11/11,7
158	119-72-103	12,4/13,2
166	119-72-103	14/14,7

TUNING: 0,75° and 89°

SET: binding PR 11 | plate PowerRail

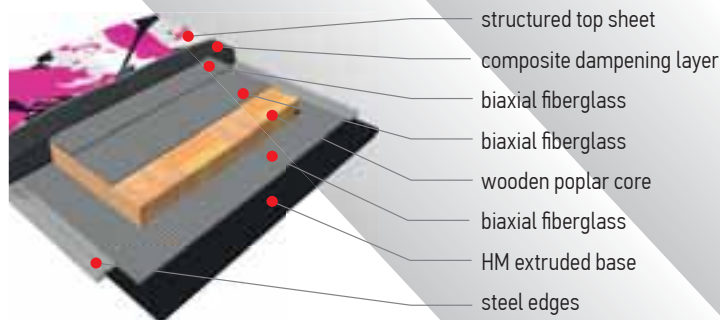

charisma



BASE: extruded base

I spend most of my time on the slope with my family. I prefer easy riding and expect my skis to forgive me a small error or two. My boys don't need to feel ashamed of me on the piste!

Joyce P., 43 years



CHARISMA – Easy-to-control skis for calm riding. For beginners as well as intermediates who care about their good looks. New shape for better control even on worse quality surfaces.

length	profile	radius
142	119-72-103	9,6/10,4
150	119-72-103	11/11,7
158	119-72-103	12,4/13,2

TUNING: 0,75° and 89°

SET: binding SX 10 | plate Power Plate 9

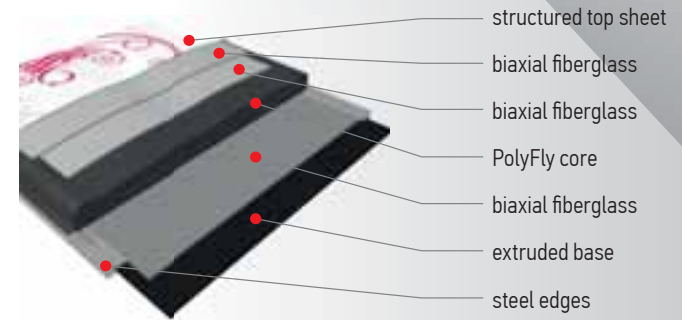

fun alpine



wolfram



BASE: HM extruded base

There's never enough fun on the piste. I have long searched for skis I could really lean on in a turn. Wolfram has finally shown me the way to funcarving.

Jim P., 29 years



WOLFRAM – Stable carving skis with a perfect control of the trajectory, especially on hard snow.

length	profile	radius
124	111-78-102	9,5
136	112-78,5-103	11,6
148	113-79-104	14,0

TUNING: 0,75° and 89°

SET: binding PR 11 | plate PowerRail

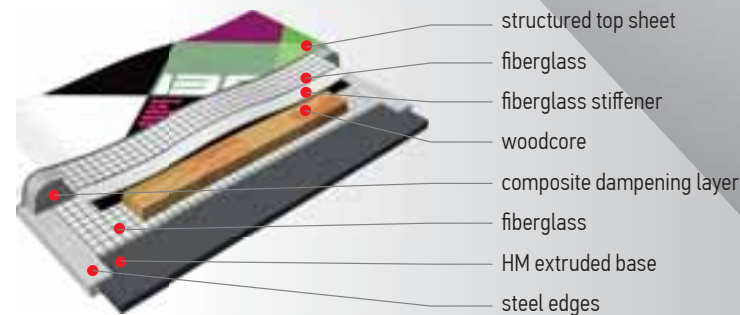

stringer

marvin



BASE: extruded base

Skiing for me means going wild. When I stand at the top of the hill, I keep asking myself where this ride is going to end... It would never be the real thing without some imagination and a bit of adrenaline!
 "Magic" Mac, 27 years



STRINGER – Skis with short edges for devoted improvisers, experienced funcarvers as well as beginners. Ideal as a spare set of skis for a family.

length	profile	radius
99	115-85-104	6,3

TUNING: 0,75° and 89°

SET: binding UNI | plate SP Curve

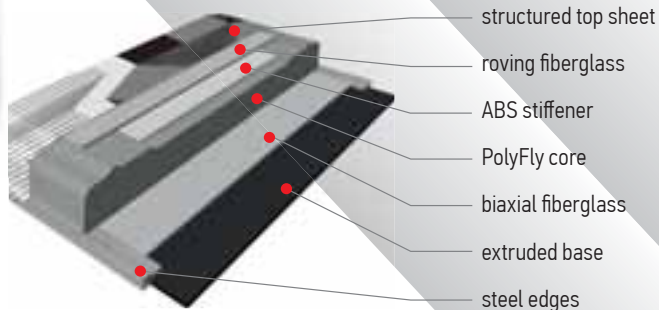

BASE: extruded base

To cut it short – short skis are so much more fun than long ones!

Tony S., 19 years



MARVIN – Non-traditional skis for non-traditional skiing experience. Also good for training.

length	profile	radius
80	125-95-115	3,3

TUNING: 0,75° and 89°

SET: binding UNI

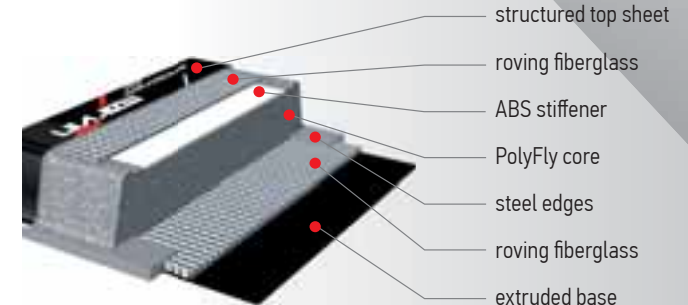

free guru



BASE: HM Graphite base

Mountains are a challenge for me. I love the feeling of setting out into fresh powder and conquering hills off-road style. But whenever I feel so, I take off the straps from my skis and head for the piste. That's where I need speed!

Tom „Grizzly“ D., 33 years

FREE GURU – Touring skis for ski-mountaineering with a light-weight wooden core for extraordinarily low weight. 81 mm width is suitable for skiing on both groomed and ungroomed tracks.



length	profile	radius
154	124-81-111	12,2
162	124-81-111	13,8
170	124-81-111	15,4
178	124-81-111	17,1

TUNING: 0,75° and 89°

SET: binding Ambition 12

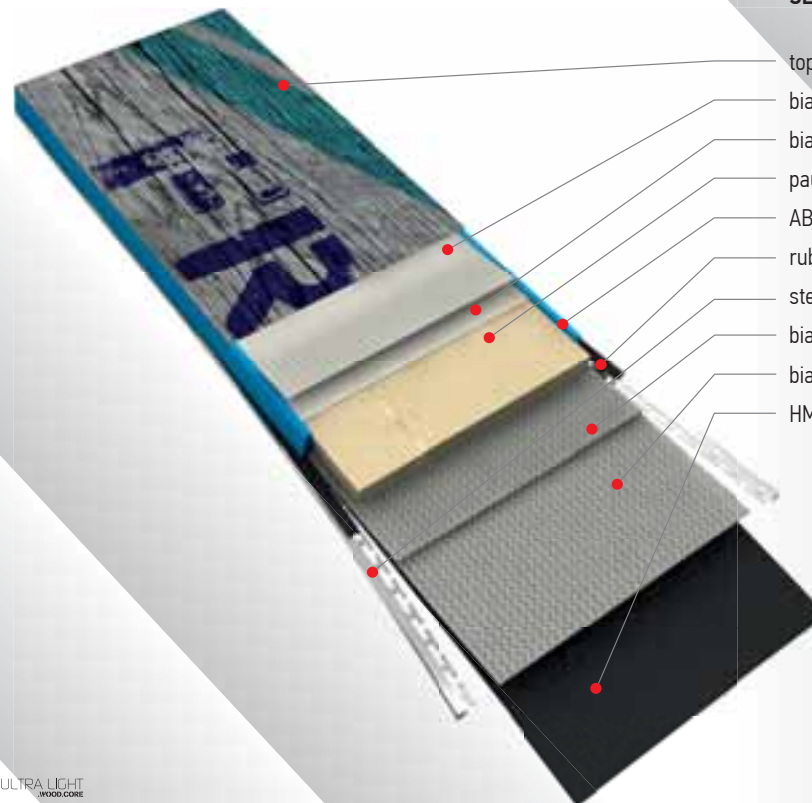

- top sheet
- biaxial fiberglass
- biaxial fiberglass
- paulownia wood core
- ABS sidewalls
- rubber
- steel edges
- biaxial fiberglass
- biaxial fiberglass
- HM Graphite base

24-25

junior
alpine

collection 2014/15



www.sporten.cz

SPORTEN



ahv jr GS

ahv jr SL



BASE: UHM Graphite race base

My coach and I have had a long discussion about what skis would suit me best. Finally we've decided for AHV JR GS. These skis give me great support in a race, but even when I go for a ride with my mates, I never get tired of them.

Pete V., 13 years



AHV JR GS – Ideal skis for junior training and racing in alpine disciplines.

length	profile	radius
150	102-65-88	15,6
159	102-65-88	17,8
168	102-65-88	20,0

TUNING: 0,75° and 88°

SET: binding FF 11 | plate Race Plate Junior

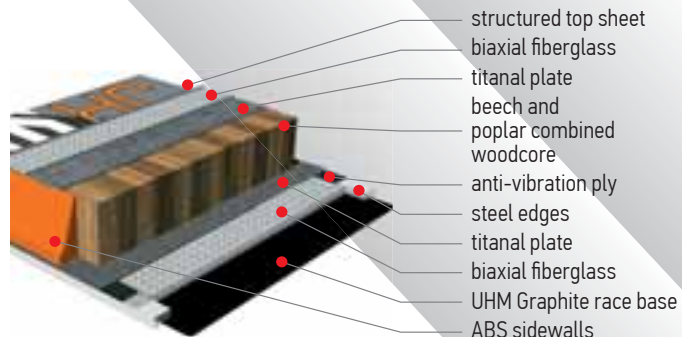

BASE: UHM Graphite race base

I'm the oldest one in our team, so I must inspire the other girls too. Not only by good results or a strong mind, but also by choosing the right ski. All of us are training on Sporten skis now!

Nicky H., 14 years



AHV JR SL – Ideal skis for junior training and racing in alpine disciplines.

length	profile	radius
130	109-65-96	8,9
139	109-65-96	10,4
148	109-65-96	11,9

TUNING: 0,75° and 88°

SET: binding FF 11 | plate Race Plate Junior

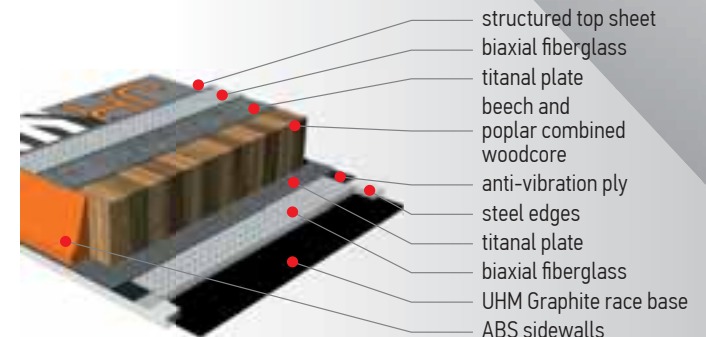

citypark

x-fighter JR



I wished for a new pair of skis because the old one wasn't good enough for those cool tricks big boys can do. And then, riding with Mum and Dad on a flat slope was so dull... Now at last I can have some real fun on bumps!

Bobby, 9 years



CITYPARK – Skis with a twin-tip construction for training on groomed pistes as well as in snowparks.

length	profile	radius
124	111-78-102	9,5
136	112-78,5-103	11,6
148	113-79-104	14,0

BASE: extruded base

TUNING: 0,75° and 89°

SET: binding LRX 9 Wide 90 | plate Lite Rail

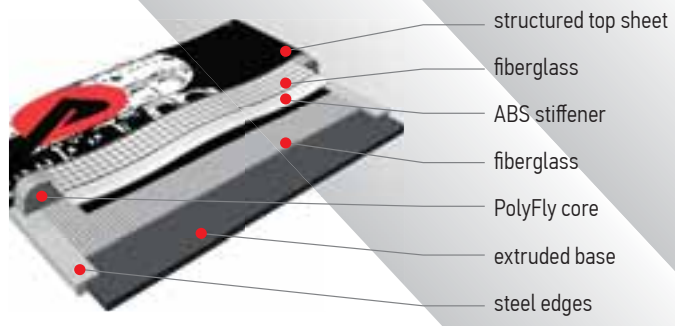

I can't wait to go on our school ski trip. I'm the only one in my class to have X-FIGHTERS. The boys envy me the way I ski and the girls think my skis really awesome.

Matt D., 10 years



X-FIGHTER JR – Boys skis with easy-to-adjust binding for improving of riding technique and style. New shape for even better control and stability.

length	profile	radius
120	104-68-90	9
130	108-68-93	10
140	108-68-93	12

BASE: extruded base

TUNING: 0,75° and 89°

SET: binding LRX 7.5 AC | plate Lite Rail

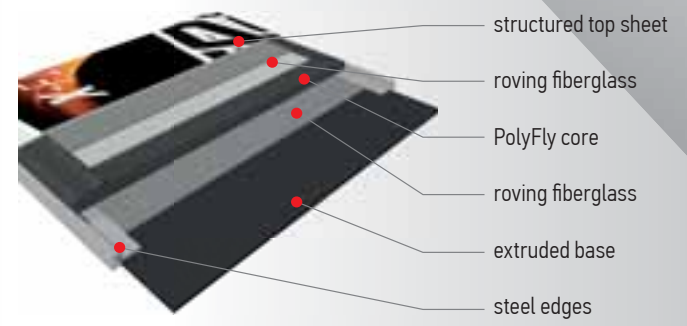

gangster JR



BASE: extruded base

I got a new pair of skis for my birthday. I took them to the biggest piste around. I wasn't afraid at all and didn't fall even once. My Dad was proud to see me doing such nice turns. I felt really great.

Simon S., 8 years



GANGSTER JR – Boys skis ideal for guidance and development of basic skiing skills. New shape for even better control and stability.

length	profile	radius
120	104-68-90	9
130	108-68-93	10
140	108-68-93	12

TUNING: 0,75° and 89°

SET: binding SX 7.5 AC

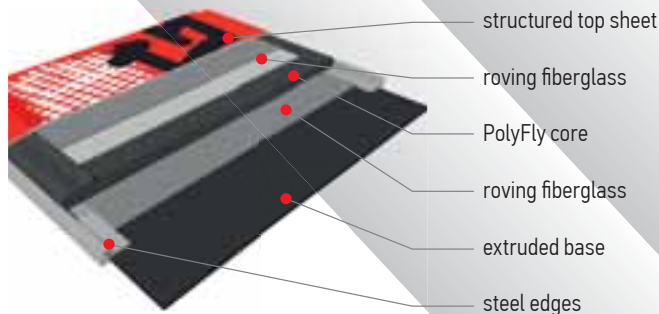

twinlight



BASE: extruded base

Not long ago my friends and I went skiing only on the hill behind the hotel. How terribly boring! But then we decided to try the big piste – now that was really awesome! And what's more – Martin simply loves my Twinlights!!

Susie, 13 years



TWINLIGHT – Girls skis for gaining experience on real pistes. New shape for even better control and stability.

length	profile	radius
120	104-68-90	9
130	108-68-93	10
140	108-68-93	12

TUNING: 0,75° and 89°

SET: binding SX 7.5 AC

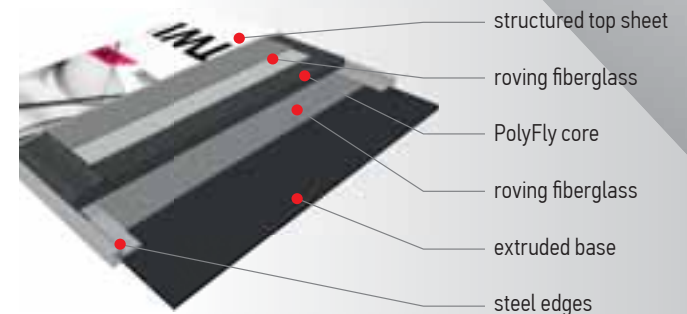

kid alpine



x-fighter



BASE: extruded base

Our seven-year-old Kate has said it straight – she wants to ski as good as her bigger brother. This year, she inherited his skis on which he used to learn skiing too. And as the binding is so easy to adjust, there was absolutely no problem.

Ted B., Dad of 7-year-old Katie



X-FIGHTER – Skis for kids with easy-to-adjust binding for first skiing experience on a real piste. New shape for even better control and stability.

length	profile	radius
70	98-66-86	2,8
80	98-66-86	4
90	102-68-88	5
100	102-68-88	6,4
110	104-68-90	7,5

TUNING: 0,75° and 89°

SET: binding LRX 4.5 AC | plate Lite Rail

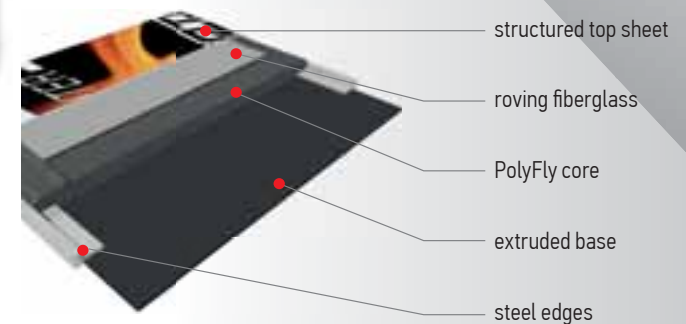

gangster

bugaboo



BASE: extruded base

Only last winter, I had to pull Danny on the sledge all the time. He didn't even manage to make a scratch on his first ski. But now, he won't pull the new Gangsters off his feet! And the sledge? He doesn't even know it exists!

Ben R., Dad of 7-year-old Daniel



GANGSTER – Skis for kids for the very first experience on a real piste. New shape for even better control and stability.

length	profile	radius
70	98-66-86	2,8
80	98-66-86	4
90	102-68-88	5
100	102-68-88	6,4
110	104-68-90	7,5

TUNING: 0,75° and 89°

SET: binding SX 4.5 AC

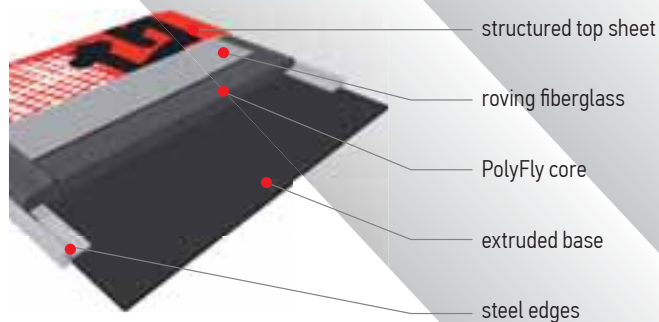

BASE: extruded base

When I was looking for the first skis for out little Annie, I found Sporten Bugaboo. Not only she's making rapid progress, she's also managed to learn her right and left (each ski has a different colour).

Sally T., Mum of 5-year-old Annie



BUGABOO – Ideal for the very first experience on a real piste. New shape for even better control and stability, original design with colour differentiation in each ski.

length	profile	radius
70	98-66-86	2,8
80	98-66-86	4
90	102-68-88	5
100	102-68-88	6,4

TUNING: 0,75° and 89°

SET: binding LRX 4.5 AC | plate Lite Rail

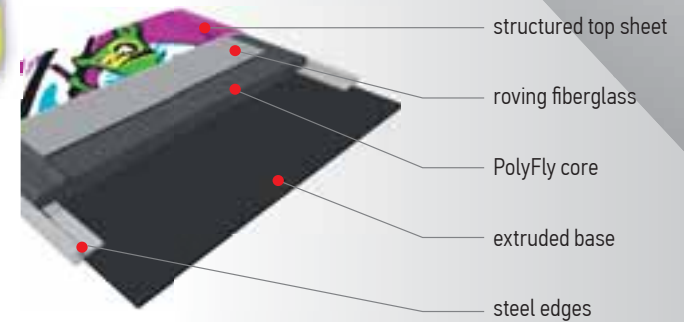

recommended lengths of nordic skis and poles

Length of skis [cm]	FAVORIT	FAVORIT W	FAVORIT JR	FAVORIT RELAX	RUBICON	HIGHLANDER	FORESTER	RANGER	PERUN W	PERUN	PERUN NATURAL	PERUN PRO	SPRINT EVO COMBI	BOHEMIA SUPER classic	BOHEMIA SUPER skate	BOHEMIA SUPER JR classic	BOHEMIA SUPER JR skate	BOHEMIA PLUS classic	BOHEMIA PLUS skate
100			14-24																
110			16-26																
120			18-28																
130			20-30																
140			22-32																
142																22-30			
147																	30-40		
150			25-37																
152																25-35			
157																	35-45		
160			30-42					58-68											
162																30-40			
164					65-80														
166									50-60	60-75	60-75	55-70							
167																	40-50		
170		38-49	38-49	47-60			50-60	68-78											
172					80-95												35-45		
174									60-70	75-90	75-90	70-85							
177																			
179													45-55			50-65			50-65
180	45-60	45-60		57-70	90-105	53-63	60-70	78-90						50-65				50-65	
181																			
182									70-80	85-100	85-100	80-95							
185	50-65	50-65				58-68									65-85				65-85
187													55-65						
188														65-80				65-80	
189																			
190	57-71	57-71		67-82		67-76	70-85	86-98		95-110	95-110	90-105							
193																80-100			80-100
195	62-78	62-78				69-80							65-80						
196														75-90				75-90	
197																			
198										100-115	100-115	100-115							
200	69-85	69-85		77-92		75-86	80-95	94-106											
201																			
203													80-95						
204														85-100				85-100	
205	77-94					83-94													
208																			
210	84-100			87-102		90-103	90-105												

Height of skier [cm]	Skating [cm]	Classic [cm]	Touring [cm]
195	176	166	160
190	171	161	156
185	167	157	152
180	162	153	147
175	158	149	143
170	153	145	140
165	149	140	135
160	144	137	131
155	140	132	127
150	135	128	123
145	130	123	119
140	126	119	115
135	122	115	110
130	117	111	106
125	113	106	102
120	108	102	98

The table is informative only. The right length of ski will be recommended by expert shop staff with respect to your skiing style and the terrain you will go skiing in. The final choice can be different from that written in the table.

collection 2014/15



www.sporten.cz

sport
nordic

SPORTEN



bohemia plus classic

bohemia plus skate



BASE: UHM NANO Graphite race base

Once in a white track, I am unlimited. I can be hard on myself and I know what I'm doing. This sport is not what I do for living, still I could hardly imagine my life without it.

Ron, 36 years

BOHEMIA PLUS CLASSIC – New racing skis will give you the lightness and strength necessary for winning. Unsuitable for ungroomed tracks.

CLASSIC	length	profile	for weight
	180	44-45-45	50-65
	188	44-45-45	65-80
	196	44-45-45	75-90
	204	44-45-45	85-100

The weight of one pair of skis at the length of 196 cm is 1120g.

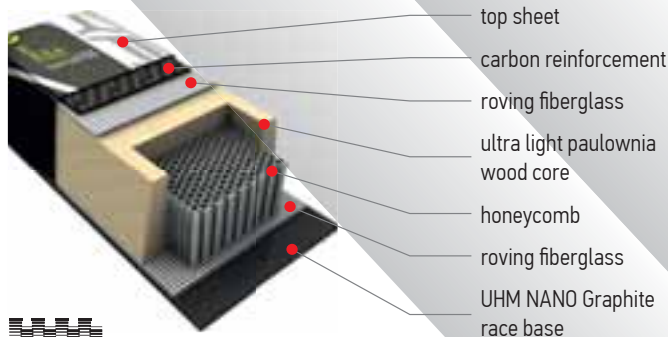

- top sheet
- carbon reinforcement
- roving fiberglass
- ultra light paulownia wood core
- honeycomb
- roving fiberglass
- UHM NANO Graphite race base

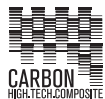

BASE: UHM NANO Graphite race base

It's not always a medal winning competition. But going "easy weasy" is not my style. I prefer hard work so that each ride is also about hard training.

Nicole, 23 years

BOHEMIA PLUS Skate – New racing skis that will give you the lightness and strength necessary for winning. Not suitable for ungroomed tracks.

SKATE	length	profile	for weight
	177	44-45-45	50-65
	185	44-45-45	65-85
	193	44-45-45	80-100

The weight of one pair of skis at the length of 193 cm is 1180g.

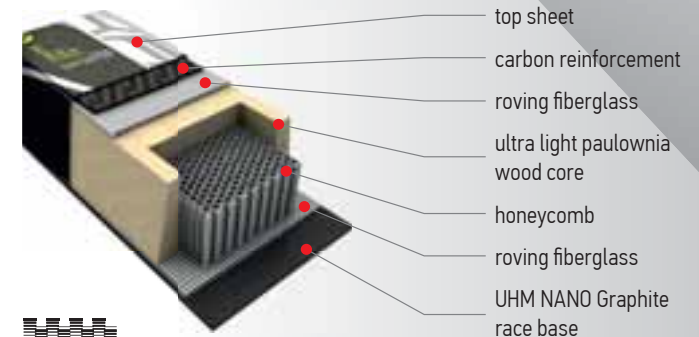

- top sheet
- carbon reinforcement
- roving fiberglass
- ultra light paulownia wood core
- honeycomb
- roving fiberglass
- UHM NANO Graphite race base



bohemia super classic

bohemia super skate



BASE: UHM Graphite race base

Over the years I came to understand that the art of losing is nothing more than an alibi for weaklings. I love winning and I'm not ashamed of it. And I tell you, the Bohemias are the best Nordic skis I've ever had.

Harry T., 44 years

BOHEMIA SUPER CLASSIC – Fast and light racing skis offering uncompromising quality.

CLASSIC	length	profile	for weight
	180	44-45-45	50-65
	188	44-45-45	65-80
	196	44-45-45	75-90
	204	44-45-45	85-100

The weight of one pair of skis at the length of 196 cm is 1250 g.

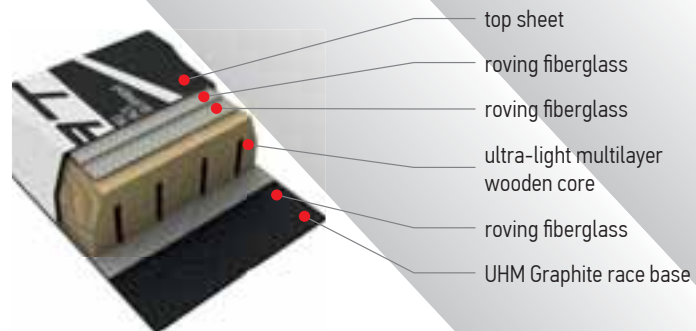

BASE: UHM Graphite race base

I was born in Finland, so to say “with skis on my feet”. Ten years ago my parents and I came to live in the Czech Republic and my racing skis stayed at home. I've long been searching for something to replace them when at last I've found what I wanted...

Olaf W., 23 years

BOHEMIA SUPER Skate – Fast and light racing skis offering uncompromising quality.

SKATE	length	profile	for weight
	177	44-45-45	50-65
	185	44-45-45	65-85
	193	44-45-45	80-100

The weight of one pair of skis at the length of 193 cm is 1260 g.

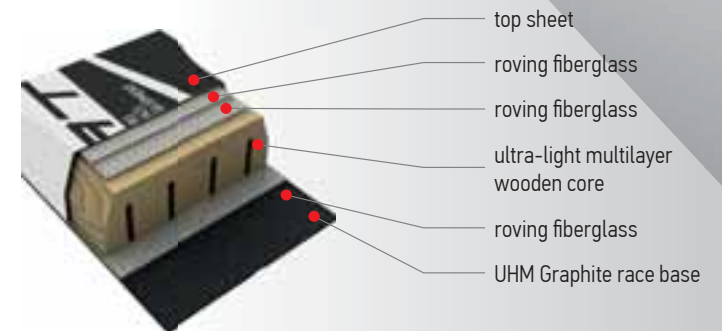

sprint evo combi

perun pro



BASE: HM Graphite base

I prefer buying top quality stuff that works as it should and that is 100% reliable. Good skis must support me in the track, be fast, light, but also fun.

Philip C., 21 years

SPRINT EVO COMBI – High performance skis for a technically competent, universal cross-country skier.

length	profile	for weight
179	45-45-45	45-55
187	45-45-45	55-65
195	45-45-45	65-80
203	45-45-45	80-95

The weight of one pair of skis at the length of 195 cm is 1350 g.

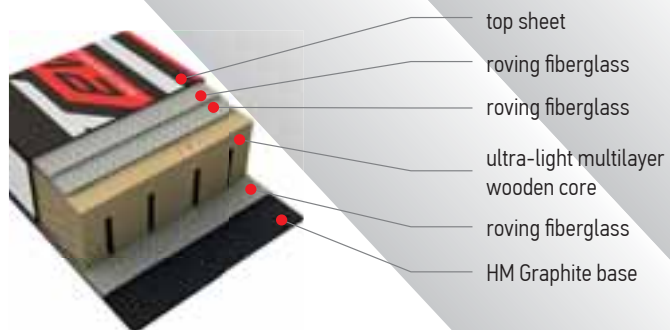

ULTRA LIGHT
WOOD CORE



BASE: HM Graphite base

I love sport so I prefer skiing in a well groomed track. But at my family's call, we set off for adventures. Snow always means fun. And the wax is a part of it!

Richie J., 39 years

PERUN PRO – Top category power fit Nordic skis will give you the right push-off, high quality ski base will take you for an easy ride, but it needs waxing. An option for heavier skiers instead of combi Nordic skis.

length	profile	for weight
166	51-46-48	55-70
174	51-46-48	70-85
182	51-46-48	80-95
190	51-46-48	90-105
198	51-46-48	100-115

The weight of one pair of skis at the length of 182 cm is 1350 g.

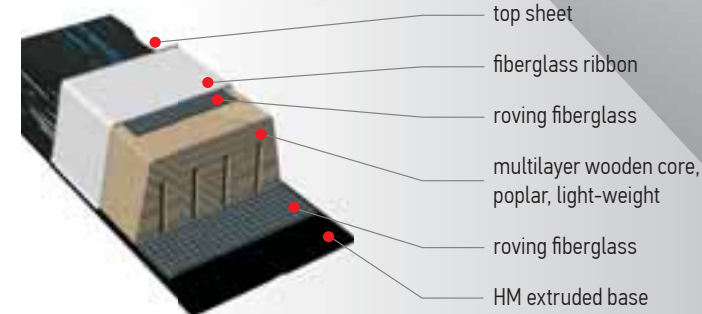

Wax base.

WOOD CORE



collection 2014/15



www.sporten.cz

power fit
nordic

SPORTEN



perun

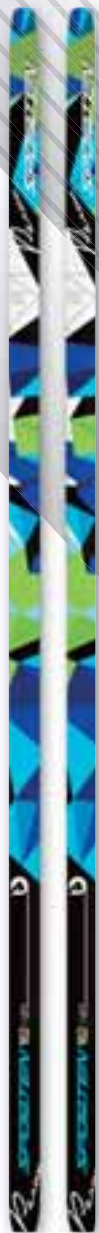

BASE: extruded base

With my body-build (105 kg) I need skis that are not afraid of overload. My skis forgive me my style and still give me the feeling I'm outdoing myself.

Tim, 29 years

PERUN – Easy-to-control skis for an easy-going ride, with or without a multigrip base requiring no climbing wax.

length	profile	for weight
166	51-46-48	60-75
174	51-46-48	75-90
182	51-46-48	85-100
190	51-46-48	95-110
198	51-46-48	100-115

Options: wax base or multigrip embossed.

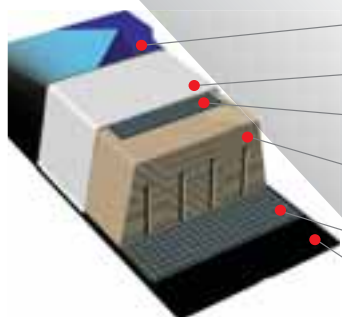

- top sheet
- fiberglass ribbon
- roving fiberglass
- multilayer wooden core, poplar, light-weight
- roving fiberglass
- extruded base

perun set



Do you need complete ski equipment and are you looking for quality at a good price? You're in the right place!

Again this year we have prepared a SPORTEN nordic ski package at a reasonable price.

- SPORTEN Perun nordic skis
- SPORTEN Perun Man boots
- SPORTEN Carbon poles
- SNS auto man binding



perun natural

rubicon



BASE: extruded base

I remember days when skis used to be two pieces of bent wood. Times have changed. My new skis do almost all the work for me without bothering about my weight. And their wooden look makes me feel young again.

Edward O., 63 years

PERUN Natural – Easy-to-control skis for an easy-going ride, with or without a multigrip base requiring no climbing wax. Load capacity over 100 kg.

length	profile	for weight
166	51-46-48	60-75
174	51-46-48	75-90
182	51-46-48	85-100
190	51-46-48	95-110
198	51-46-48	100-115

Options: wax base or multigrip embossed.

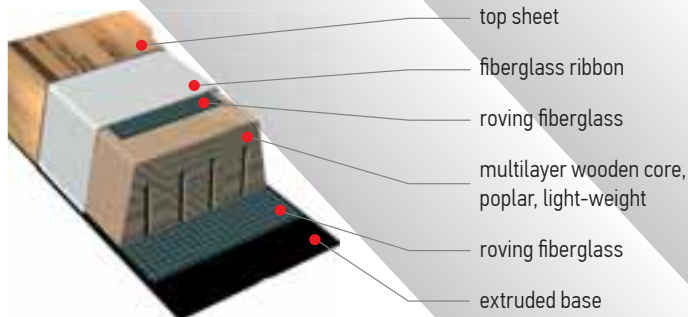

BASE: extruded base

The moment I was waiting for the whole year. Two white lines crossing the winter landscape – this moment is there just for me. And I will enjoy it.

Monty P., 44 years

RUBICON – Robust, stable skis eliminating technical shortcomings, with a multigrip base requiring no climbing wax.

length	profile	for weight
164	62-56-60	65-80
172	62-56-60	80-95
180	62-56-60	90-105

Multigrip embossed.

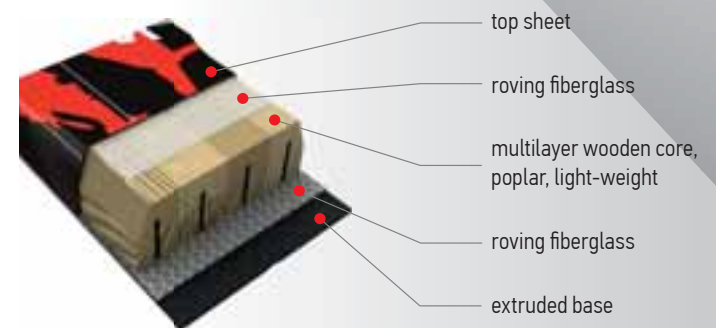

touring nordic

favorit relax

For all my life I have been following the principle that "every journey leads to a destination". I want to enjoy every move while savouring the scenery around. And when the skis start to go faster than I want, the extended multigrip will teach them to behave.

William Anthony J., 68 years

FAVORIT – Universal touring skis offering stability and reliability in any circumstances. Extended multigrip included.

length	profile	for weight
170	60-50-55	47-60
180	60-50-55	57-70
190	60-50-55	67-82
200	60-50-55	77-92
210	60-50-55	87-102

BASE: extruded base

Multigrip embossed.

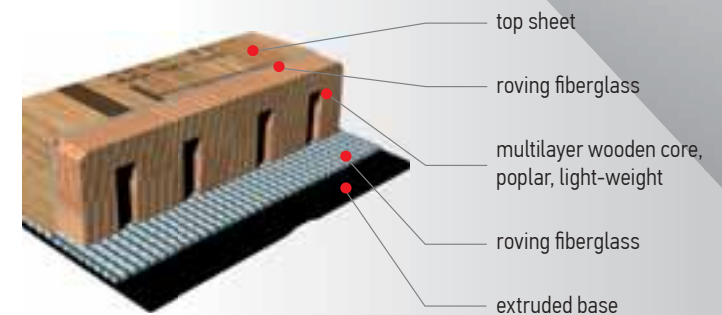

WOOD.CORE



favorit

favorit set

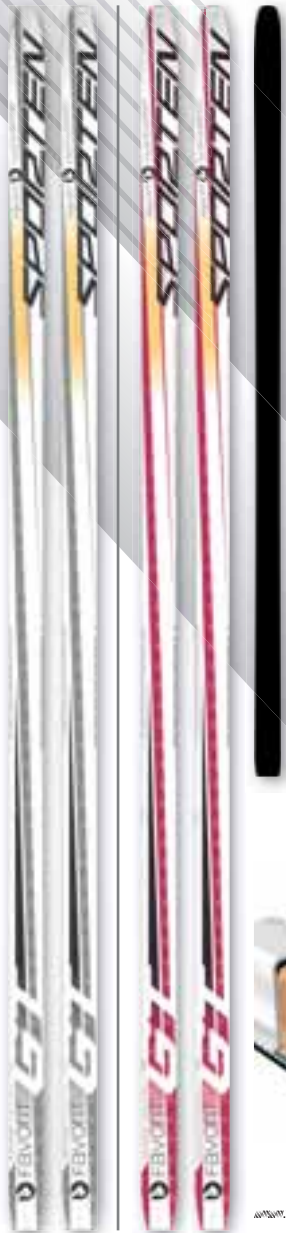

BASE: extruded base

There's no way of keeping me home when the first snow is down. Favourite time of the year, favourite sport, FAVORIT skis!

Henry S., 56 years

FAVORIT – Universal touring skis offering stability and reliability in any circumstances. Multigrip on demand.

length	profile	for weight
180	54-48-52	45-60
185	54-48-52	50-65
190	54-48-52	57-71
195	54-48-52	62-78
200	54-48-52	69-85
205	54-48-52	77-94
210	54-48-52	84-100

Options: wax base or multigrip embossed.

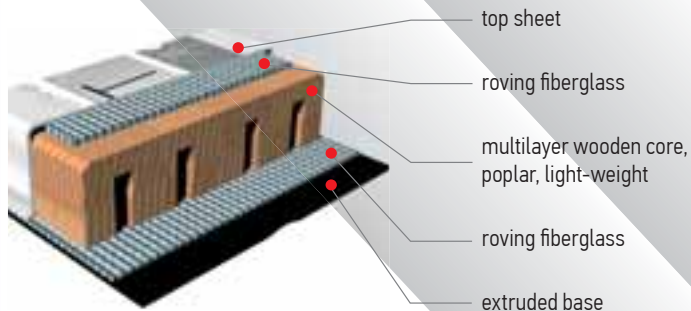

WOOD.CORE

Do you need complete ski equipment and are you looking for quality at a good price? You're in the right place!

Again this year we have prepared a SPORTEN nordic ski package at a reasonable price.



- SPORTEN Favorit nordic skis
- SPORTEN Favorit boots
- SPORTEN Alu poles
- SNS auto man/woman binding



40-41

lady nordic

perun w



collection 2014/15



www.sporten.cz



BASE: extruded base

To be honest, I like being spoiled. I need skis that will guide me in the track, that won't need waxing and will be worth looking at by men as much as I am.

Sandra, 26 years

PERUN WOMAN – Easy-to-control skis for relaxed skiing, with a multigrip base requiring no climbing wax. Trendy look.

length	profile	for weight
166	51-46-48	50-60
174	51-46-48	60-70
182	51-46-48	70-80

Multigrip embossed.

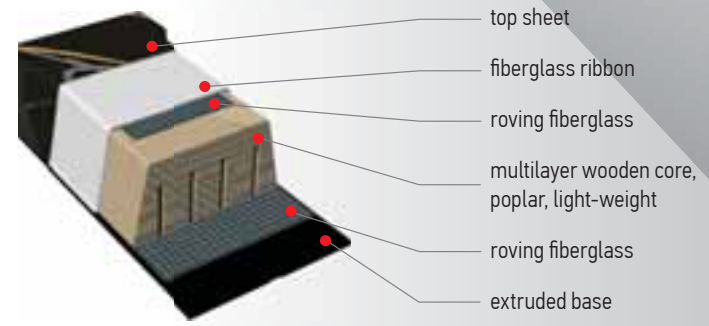

WOOD.CORE



perun W set

Do you need complete ski equipment and are you looking for quality at a good price? You're in the right place!

Again this year we have prepared a SPORTEN nordic ski package at a reasonable price.

- SPORTEN Perun W nordic skis
- SPORTEN Perun Woman boots
- SPORTEN Carbon poles
- SNS auto woman binding



favorit W

Skiing for me is mostly about fun and relax. Fresh air activities are good for me as well as for my children. We are a Sporten skiing family.

Diane, 35 years

FAVORIT WOMAN – Ladies touring skis offering stability and reliability in any circumstances, with elegant design.

length	profile	for weight
170	54-48-52	38-49
180	54-48-52	45-60
185	54-48-52	50-65
190	54-48-52	57-71
195	54-48-52	62-78
200	54-48-52	69-85

BASE: extruded base

Options: wax base or multigrip embossed.

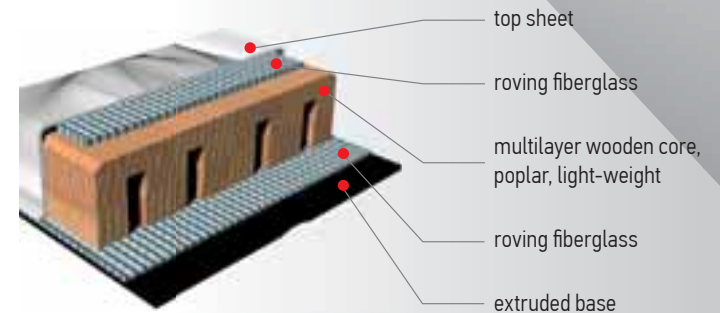

junior & kid nordic



collection 2014/15



www.sporten.cz

bohemia super JR

Last year I started to work hard training with my Dad. I want to become a member of a cross-country team. Winter Olympics is my dream.

Jon D., 11 years

BOHEMIA SUPER JR – Fast, light skis offering quality that meet the demands of a junior racer.

CLASSIC	length	profile	for weight
	140	45-45-45	22-30
	150	45-45-45	25-35
	160	45-45-45	30-40
	170	45-45-45	35-45

SKATE	length	profile	for weight
	137	45-45-45	25-35
	147	45-45-45	30-40
	157	45-45-45	35-45
	167	45-45-45	40-50

BASE: UHM Graphite race base

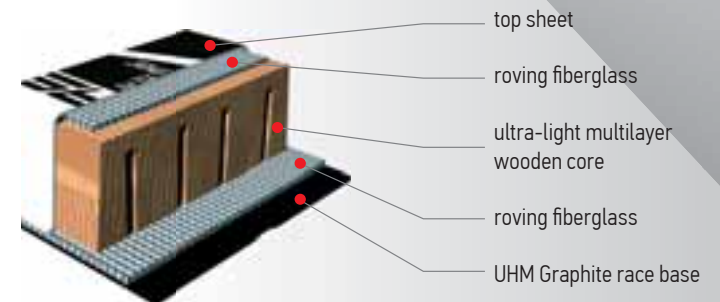

ULTRA LIGHT
WOOD CORE

favorit JR

favorit JR set



BASE: extruded base

I can't wait when I set off for the mountains! I used to do only downhill skiing because I wasn't good at cross-country. But with my new FAVORIT skis I started to enjoy it and even do not fall anymore.

Willie, 10 years

FAVORIT JR – Universal junior skis offering stability and reliability for cross-country skiing beginners. Multigrip base included.

length	profile	for weight
100	54-48-52	14-24
110	54-48-52	16-26
120	54-48-52	18-28
130	54-48-52	20-30
140	54-48-52	22-32
150	54-48-52	25-37
160	54-48-52	30-42
170	54-48-52	38-49

Options: multigrip.

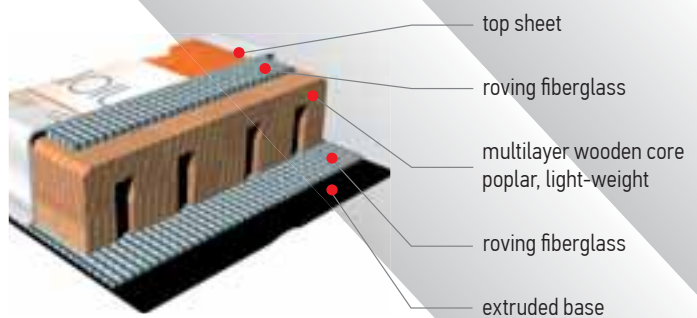

WOOD CORE

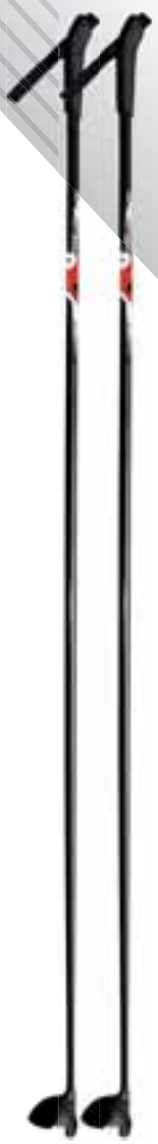

Do you need complete ski equipment and are you looking for quality at a good price? You're in the right place!

Again this year we have prepared a SPORTEN nordic ski package at a reasonable price.

- SPORTEN Favorit JR nordic skis
- SPORTEN Favorit JR boots
- SPORTEN Alu poles
- SNS auto junior binding



backcountry nordic



collection 2014/15



www.sporten.cz

highlander



BASE: extruded base

There's no dispute I can beat any bloke. Strain, discomfort, tiredness... I don't care. When I go skiing with my grandchildren, they've got hard time catching up with me.

Paula N., 61 years

HIGHLANDER – Exceptionally resilient skis, adaptable to any terrain. Solid wooden core, sharp edges. Suitable also for tracks.

length	profile	for weight
180	54-48-52	53-63
185	54-48-52	58-68
190	54-48-52	67-76
195	54-48-52	69-80
200	54-48-52	75-86
205	54-48-52	83-94
210	54-48-52	90-103

Options: wax base
or multigrip embossed.

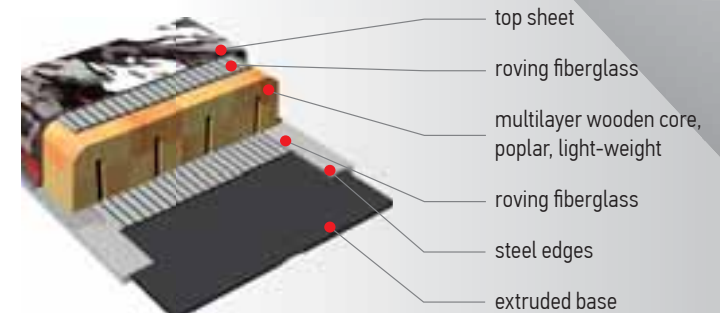

WOOD.CORE

STEELEDGES

forester



BASE: extruded base

Uncharted paths, that's what I like. There are still such places in our mountains. But that's as much as I'm willing to tell you.

Stan, 37 years

FORESTER – Skis with universal geometry enabling skiing in every weather, in all kinds of terrain, including tracks. Wooden core and steel edges.

length	profile	for weight
170	60-50-55	50-60
180	60-50-55	60-70
190	60-50-55	70-85
200	60-50-55	80-95
210	60-50-55	90-105

Options: wax base or multigrip embossed.

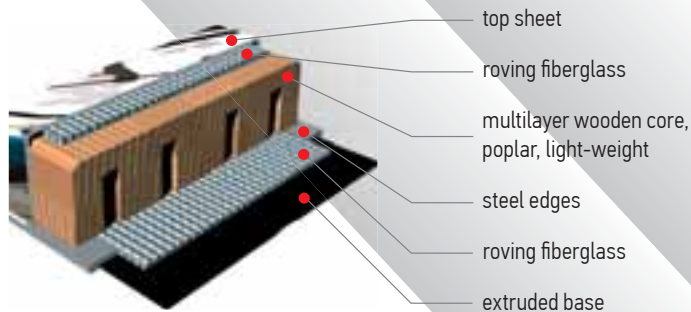

ranger



BASE: extruded base

As a gamekeeper I know every inch of my forest. Looking after wild game in the mountains is a work for tough guys. And getting where I am needed most requires reliable skis.

Bob "The Mountain" G., 37 years

RANGER – Robust skis with steel edges, coping even with deep snow and ice. Increased load bearing capacity.

length	profile	for weight
160	68-60-65	58-68
170	68-60-65	68-78
180	68-60-65	78-90
190	68-60-65	86-98
200	68-60-65	94-106

Options: wax base or multigrip embossed.

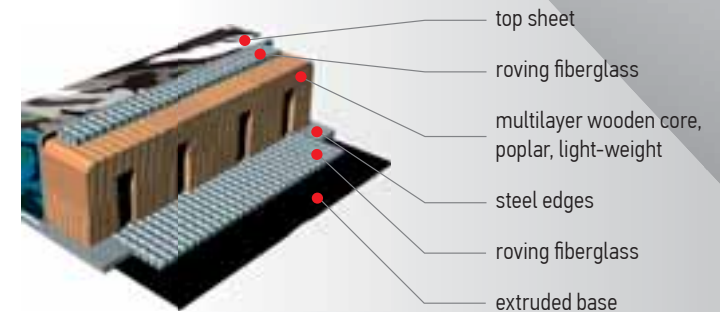

open moulds for other OEM production

collection 2014/15



www.sporten.cz

alpine

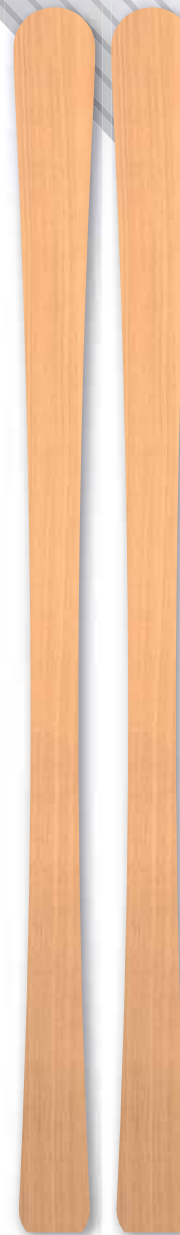

		sizes [cm]	sidecut
composite core	TX3 mould	80, 92, 104	100-67-86
		110, 116, 128, 140	104-67-90
	Daemon mould	140, 150, 160, 170	110-66-96
	Limber mould	143, 151, 162, 173	107-68-93
	Carvo mould	78, 88, 98	95-64-84
		108	96-64-84
		118	97-64-85
		128	98-64-85
		138, 148, 158	102-64-87
S-line mould		116, 126, 136	103-68-92
wood core	Tector mould	153, 161, 169	110-68-97
	Dug mould	183, 191	138-115-127
	Bulldozer mould	194	133-112-122

nordic



	sizes [cm]	sidecut
Favorit 47 mould	100, 110, 120, 130, 140, 150, 160, 170	47-44-46
Favorit 64 mould	165, 175, 185, 195, 205	64-52-60
Favorit 68 mould	160, 170, 180, 190, 200, 210	68-60-65
Horal 64 mould	165, 175, 185, 195, 205	64-52-60
Favorit	90	54-48-52
Vega	140, 150, 160	45-45-45
Forester	185, 195, 205	60-50-55

snowboard



	sizes [cm]	sidecut
wood core	146	280-239-278
	152	286-245-284
	157	294-252-292
	160	298-248-296
	161	300-258-298
composite core	166	294-240-292
	110	220-196-220
	120	230-200-230
	126	250-219-250
	132	260-228-260
	138	265-229-265
	143	270-236-270
	149	280-238-280
	155	290-247-290
	159	295-258-295
163	306-262-306	

As you have found out yourselves, this catalogue presents a broad range of products in which every fan of Czech brands will find exactly the one he or she wants. Some products are innovated, some completely new. Our ideas for annual improvement and novelties are based on our yearlong experience with ski manufacturing in which we draw on a more than hundred-years-old tradition. What is equally important for our future steps, however, is the ideas and knowledge of you, the users, in the form of a much valued feedback. We sincerely believe that our customers will appreciate the efforts in creating high quality skis at a reasonable price.

alpine
nordic

www.sporten.cz

SPORTEN, a.s.

U Pohledce 1347, 592 31 Nové Město na Moravě
Czech Republic

T.: +420 566 654 344, +420 566 654 311

F.: +420 566 654 360

E.: sporten@sporten.cz

